



SPIRAC[®]
Conveying Technology

SPIROTAINER

Autofilling containment and road transport system
Screenings - Grit - Sludge

SPIROTAINER eliminates the need for a specialized screenings building and extending system capacity is as easy as adding another SPIROTAINER. Combined with SPIRAC shaftless conveyor systems, offensive waste products are transported, stored and removed from site with no operator intervention, virtually odour, vermin and insect free. A permanent onboard spiral conveyor and control system provides automated filling and level control while a robust dump door sealing system ensures leak proof transport even with a large liquefied component. Standard truck lifting devices are incorporated into the design to facilitate ease of transport. Once it has reached the destination, the SPIROTAINER is emptied by simply tilting.

Available in 10, 15 and 20 m³ capacities, suitable for screenings, grit, (screenings and grit combined) or dewatered sludge.



Typical installations



Auto changeover slidegate with flex chutes

Note odour extraction systems which draw a negative pressure in the SPIROTAINERS through the conveyor systems.



Dumping sludge



Sludge system with weigh scales and retractable chutes



Four screenings + one grit



Auto changeover with slidegate

Pick-up at the plant



Rigid hydraulic arm style shown, similar procedure for winched systems

Dimensions

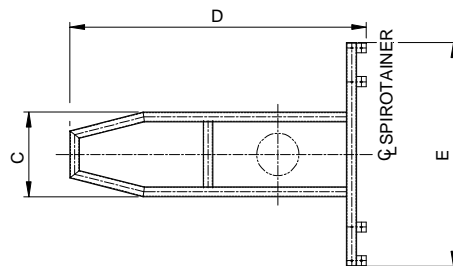
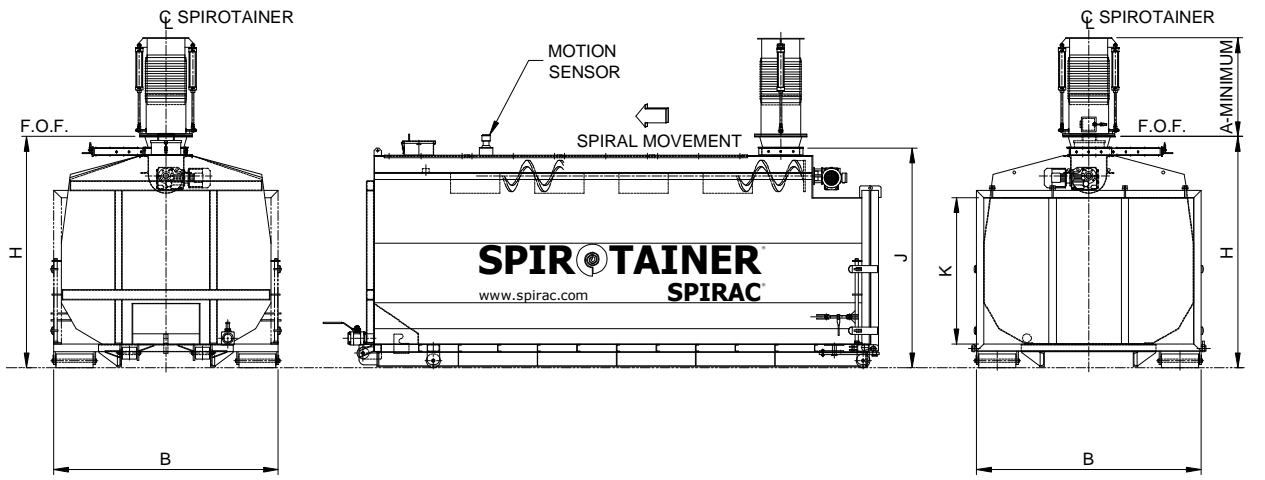
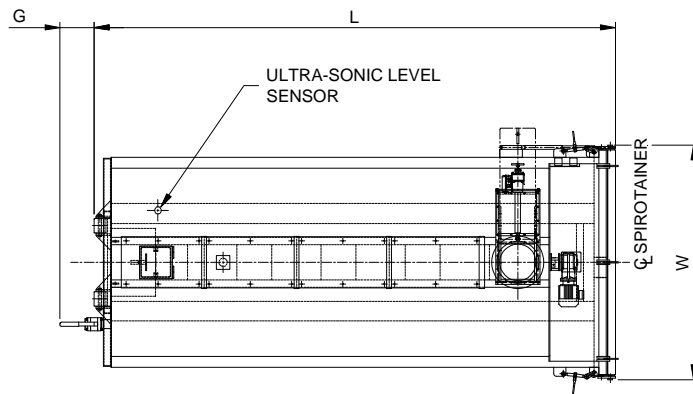

Model	Volume (m ³)	Length L	Width W	Height H	A	B	C	D	E	F	G	J	K	Weight (kg)
STU-10	10	5603	2359	1708	1000	2086	900	4396	2260	950	285	1593	850	2,750
STU-15	15	5267	2370	2334	1000	2270	900	4396	2260	950	345	2219	1475	3,500
STU-20	20	6922	2370	2334	1000	2270	900	6051	2260	950	285	2219	1475	4,000